

DRIVE BULLETIN

Model/Derivative:
Rover 75 - 1.8 petrol and 2.0 diesel saloons

Nº: DB0004 Issue 1
Date: ???.??.2002

DRIVE bulletins update:

DRIVE is a major project within MG Rover. It's objective is to significantly improve our competitiveness. The purpose of a 'DRIVE' bulletin is to advise changes introduced as a result of the MG Rover 'DRIVE' initiative.

Nº: 20048	Title: REAR ANTI-ROLL BAR DELETION	Model: Rover 75 saloon 1.8 petrol and 2.0 diesel only (excludes KV6, Tourer and all MG versions)	Introduction: June 2002 VIN to follow
---------------------	--	--	--

Detail:

The rear anti-roll bar assembly 'A' (see illustration) will be deleted from the described derivatives – change points to be issued.

To enable the same high standards of ride quality to be maintained following this deletion, the described design changes have been made to provide greater roll control:

- The standard saloon rear subframe bushes are to be replaced with a new bush that is common to both Rover 75 Saloon and Tourer. The new rear subframe has stiffer mounting bushes 'B' than the current saloon.
- The standard rear road springs 'C' have been replaced with updated springs.

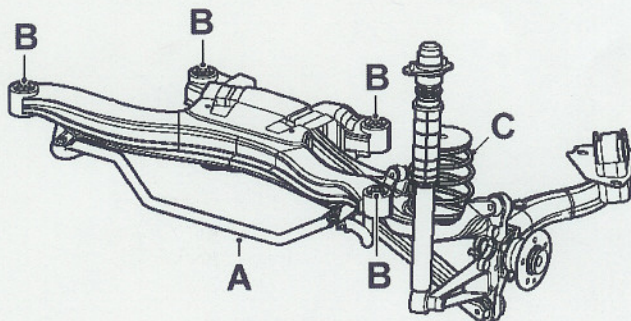

Part numbers for the replaced and new rear coil spring assemblies are as follows:

Replaced spring assembly part numbers. (with anti-roll bar) <i>Comprises spring and 2 isolators.</i>	Replaced spring Colour / Code (with anti-roll bar)	New spring assembly part numbers. (without anti-roll bar) <i>Comprises spring and 2 isolators.</i>	New spring Colour / Code
RKB101420	PINK – RB	RKB101421	WHITE - RL
RKB101430	RED – RC	RKB101431	VIOLET - RM
RKB101440	BLUE – RD	RKB101441	YELLOW - RN

For position of spring and damper identification label, see Technical Bulletin TB0060